

Aston

Design – Johan Lindstén



JOHANSON



Johanson has enjoyed many years of close collaboration with Johan Lindstén. Now we are proud to add Aston to the many other products in the Johanson range that already bear his name.

Aston is a slender stackable chair. Thanks to the understated elegance of its sleek lines, it can reflect different personalities through the choice fabric and colour of metal frame. The slender silhouette gives ASTON its lightness, while minor details such as the fastenings that connect the legs and back are hidden in the construction. Some inspiration for Aston has been borrowed from the classic Thonet café chair, whose design remains as practical and appealing today as it has always been. ASTON is the very epitome

of design that seeks to minimise the number of components and use techniques such as 3D bending without compromising appearance or comfort in any way.

“Aston is a lightweight construction with fantastic ergonomic properties and an innovative design that flirts with bygone times and styles. The 3D curve of the leg frame provides a natural ‘handle’ in the back, which makes the chair easy to move in public spaces. And there is flexibility, too, in the different finishes and alternatives,” says Johan Lindstén.

During February, we get to meet Aston with armrests. A further development of the model that creates additional comfort as well as a clear profile and shape.



Designer

Johan Lindstén's products are characterised by well-thought out design and unexpected details in a creative process that optimises function. Johan wants his designs to interact with their surroundings in a way that influences the mood of the user. He draws his inspiration from the most unlikely of sources, such as the lilac bush outside his home or the Ocean of Storms on the moon.



Models



Aston 08-46



Aston-08-46-Rattan back



Aston 08-46 WA



Aston-08-46-WA-Rattan back

Material

Seat - Upholstery materials

Johanson offers a very generous range of fabrics, leather and artificial leather from the most reputable suppliers in the world. Should any other material be desired despite the wide selection, it is also possible to suggest other materials. Johanson does not charge start-up costs for handling non-standard materials.

Multicolour - Finish RAL

Take part in Johanson's color range, 405 variants of different finishes are offered as standard on steel frames and metal details. Choose from all 195 RAL colors, alternatives are available both as solid finish (gloss 72) or Structure finish which has a matte, slightly textured elegant surface. In addition, 15 RAL colors with pearl finish.

For all colours see www.johansondesign.com

- 195 Solid collection (gloss 72)
- 195 Structure collection (matte, textured surface)
- 15 Pearl finish collection



Rattan backrest

The rattan back is available in oak, white stained oak and black stained oak.



Facts

Aston in detail

Separable

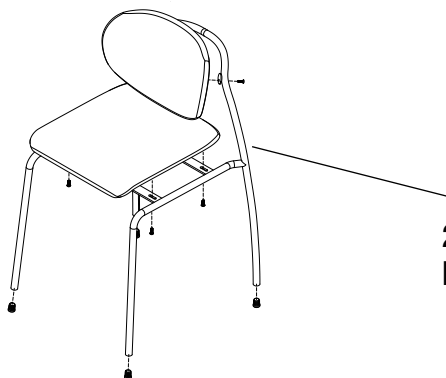

20-50%
Recycled Swedish steel

Material

The seat is made of wood and polyether. Foam which meets the highest fire classification CMHR- Combustion Modified High Resilience, is available for all models on request. The base is made of finished/lacquered metal.

Fire classification

All products meet Möbelfakta's fire requirements. All polyether/foam are tested to Cal TB 117. All standard fabrics meet EN 1021:1 & 2. Other classification, for example BS 5856 (Crib 5) on request, please contact customer support.

Recycling

All steel parts are recyclable. Before we finish the chrome/lacquer all grease/oil is removed by alkaline wash and then sent for destruction. The lacquering is produced by electrostatic epoxy powder coating that gives a minimum of waste. The electrostatic chrome (chrome 3) is recyclable. The plastic parts that are used are recyclable by grinding. All upholstery and frames of synthetic material are totally without C.F.C. emissions. All glue is water based.

Certificate



BIM - objects can be downloaded

at johansondesign.com



3D Max



Sketchup



Archicad



pCon



Revit



Autocad 2D



Autocad 3D

Facts

Measurements cm

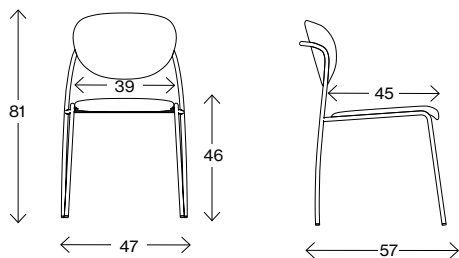

Aston 08-46

Weight (kg) 6,2
Volume (m³) 0,22



Measurements cm

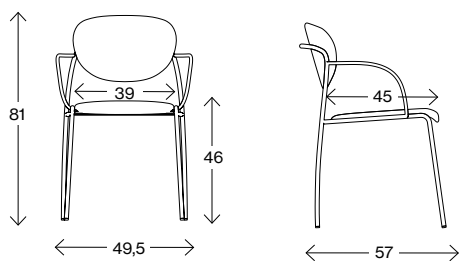

Aston 08-46 WA

Weight (kg) 6,8
Volume (m³) 0,23









JOHANSON

Johanson Design AB | Anders Anderssons Väg 7 | 285 35 Markaryd | Sweden
Tel +46-433 725 00 | www.johansondesign.com