

Family

Frankie

Design – Fredrik Färg & Emma Blanche



JOHANSON



Introduction

With their special feeling for fashion trends, the design duo Färg & Blanche have created a series inspired by trouser braces. Focus has been on emphasizing the back of their chair, Frankie, and the straps of the braces on the back give this piece of furniture an almost human identity. Frankie has been created for offices and commercial environments.

Frankie Lounge is based on the same design element as the Frankie chair – with the shape of trouser braces incorporated into the back detailing. Instead of the single steel tubes used to create the symbol for Frankie, Frankie Lounge has double tubes that sweep from the front legs to the back, which also cre-

ate a runner frame for the chair. Just like its predecessor the Lounge chair has an upholstered seat and feathered back which provide a high degree of sitting comfort.

“We had the idea for the bar stool when we were examining how we could develop the Frankie chair. We picked out aesthetic elements from the back along with details such as the jointing of the tubing. The resulting shape is like two straps holding and pressing the seat in place forming two clear folds in the seat and creating a soft look. The seat also has the same characteristic curved shape as the back of the Frankie chair with edges that fold inwards on each side,” says Fredrik Färg.



Designer

Stockholm based design studio Färg & Blanche is known for their experimental stance, where each expression informs the other, they effortlessly move between the exclusive hand made one off and the industrially produced, without ever losing their distinctive touch.



Models



Frankie 08-46



Frankie X 08-46



Frankie 09-46



Frankie X 09-46



Frankie BS 80



Frankie BS 65



Frankie Tab



Frankie EC

Material

Seat - Upholstery materials

Johanson offers a very generous range of fabrics, leather and artificial leather from the most reputable suppliers in the world. Should any other material be desired despite the wide selection, it is also possible to suggest other materials. Johanson does not charge start-up costs for handling non-standard materials.

Multicolour - Finish RAL

Take part in Johanson's color range, 405 variants of different finishes are offered as standard on steel frames and metal details. Choose from all 195 RAL colors, alternatives are available both as solid finish (gloss 72) or Structure finish which has a matte, slightly textured elegant surface. In addition, 15 RAL colors with pearl finish and chrome are offered.

For all colours see www.johansondesign.com

- 195 Solid collection (gloss 72)
- 195 Structure collection (matte, textured surface)
- 15 Pearl finish collection and chrome.



Accessories



Connector

Frankie 08-base



Stacking trolley

Stackability for each chair can be found under facts.



Connector

Frankie 09-base

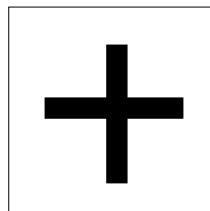

Extra

Felt gliders
Stacking protector (standard)

Facts

Material

The seat is made of FSC certified wood and padding is made of polyether/foam. Finished/lacquerd metal.

Fire classification

All products meet Möbelfakta's fire requirements. All polyether/foam are tested to Cal TB 117. All standard fabrics meet EN 1021:1 & 2. Other classification, for example BS 5856 (Crib 5) on request, please contact customer support.

Certificate



Recycling

All steel parts are recyclable. Before we finish the chrome/lacquer all grease/oil is removed by alkaline wash and then sent for destruction. The lacquering is produced by electrostatic epoxy powder coating that gives a minimum of waste. The electrostatic chrome (chrome 3) is recyclable. The plastic parts that are used are recyclable by grinding. All upholstery and frames of synthetic material are totally without C.F.C. emissions. All glue is water based.

CAD - objects can be downloaded

at johansondesign.com



3D Max



Archicad



Revit



Autocad 2D



Autocad 3D



Sketchup

 pCon

Facts

Measurements cm

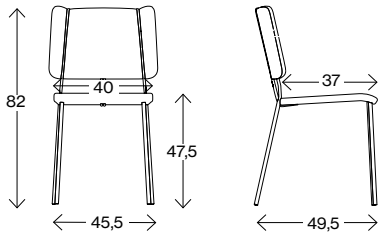

Frankie 08-46

Weight (kg)
Volume (m³)

6,0
0,19



Measurements cm

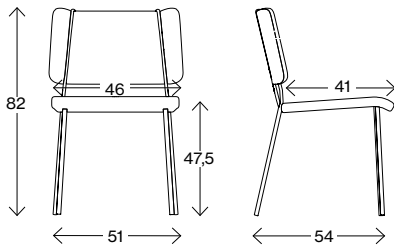

Frankie X 08-46

Weight (kg)
Volume (m³)

7,0
0,266



Measurements cm

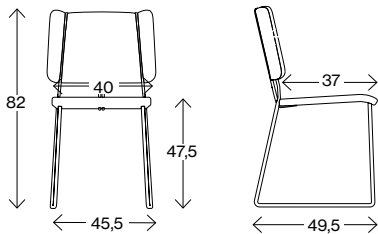

Frankie 09-46

Weight (kg)
Volume (m³)

6,8
0,19



Measurements cm

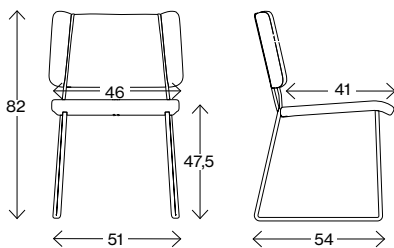

Frankie X 09-46

Weight (kg)
Volume (m³)

7,0
0,266



Facts

Measurements cm

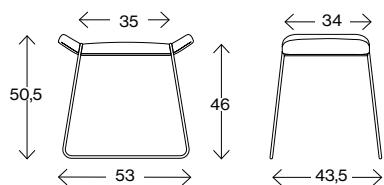

Frankie Tab

Weight (kg)
Volume (m³)

5,0
0,101



Measurements cm

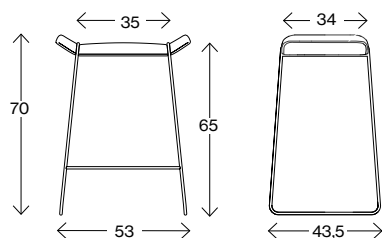

Frankie BS 65

Weight (kg)
Volume (m³)

6,0
0,19

Measurements cm

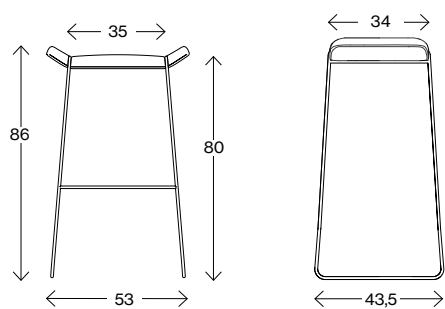

Frankie BS 80

Weight (kg)
Volume (m³)

9,0
0,24

Measurements cm

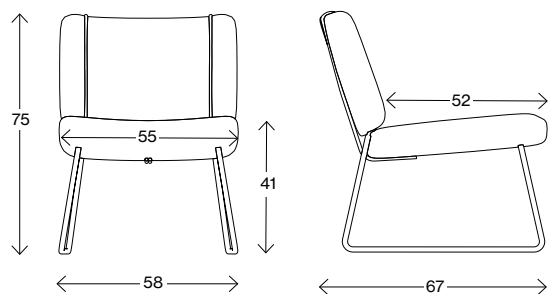

Frankie EC

Weight (kg)
Volume (m³)

12,0
0,512









JOHANSON

Johanson Design AB | Anders Anderssons Väg 7 | 285 35 Markaryd | Sweden
Tel +46-433 725 00 | www.johansondesign.com